

WÖHLER

IR Temp 210

Infrared Thermometer



Contents

1. Specification.....	14
2. Operating Elements.....	16
3. Operation.....	18
4. Maintenance.....	19
5. Information on disposal.....	19
6. Emissivity-tables	20
7. EG - Conformity Statement	22
8. Guarantee and Service.....	22

1. Specification

1. Specification

1.1 Important information

- ! Carefully study and observe all items of these operating instructions before commissioning the unit.
- ! In principle, the Wöhler IR Temp 210 should only be used by skilled personnel for its intended purpose and within the specified range of data. Any liability or warranty for results established or for defects caused when using the unit is excluded by all means.
- ! Use the thermometer with extreme caution when the laser beam is turned on. The potential damage it could cause is for hundreds feet away.
- ! Do not point the laser toward the eyes or face of a person or animal.
Never look into the laser because it could damage your eyes seriously.
Be careful not to point the beam on a reflective surface, it could be reflected directly and damage your eyes or the eyes of other persons. Protect your eyes if it is necessary to use the thermometer in a reflective environment.
- ! It is forbidden to beam on any gas which explodes.

1.2 Application

The Infrared Thermometer Wöhler IR Temp 210 is used for measuring temperature without contact with the target. It provides the possibility to select the adequate emissivity for your measurement. An optional laser pinpointing method makes the identification of the central point of the measuring surface area possible.

1. Spezifikation

1.2 Technical Data:

Measuring Range:	- 40 to + 500 °C (-40 to 932 °F)
Accuracy:	± 2 % of reading or ± 2 °C
Resolution:	0,1 °C /°F
Distance/Spot Ratio:	10:1
Response Time:	1 sec
Power Consumption:	12 mA
Max. capacity:	1 mW
Wave length:	670 nm
Operating Humidity:	max. 80 % RH
Display:	LCD display with backlighting
Power Supply:	9 V battery
Emissivity setting:	0,3 to 1,0
Auto power off:	after 10 seconds
Size:	160 x 50 x 33 mm
Weight:	140 g

1.3 Optics

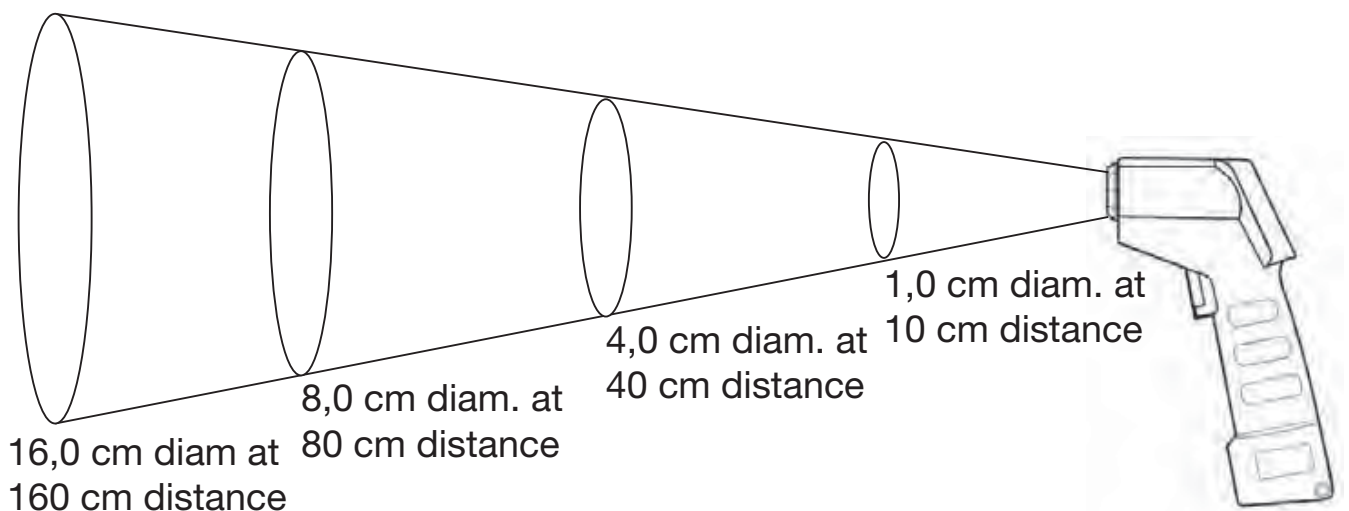

2. Operating Elements

2. Operating Elements

2.1 Front



- 1 LC-Display
- 2 °C/°F select key
- 3 Emissivity select key (Mode)
- 4 Laser key
- 5 Backlighting key

2. Operating Elements

2.2 Side view



1. Trigger

2. Battery compartment

2.3 Display



1. Temperature unit

2. Emissivity indicator

3. Data hold

3. Operation

3. Operation

3.1 Temperature measuring

The Wöhler IR Temp 210 has a laser pointer beam to mark the measuring area on the object.

Turn the instrument on by pressing the blue trigger. If you only press the trigger for a short moment, the display will show the actual value. After approximately 10 seconds the meter will turn off automatically.

If you hold the trigger, the meter will automatically start measuring.

To turn the laser pointer on, press the **LASER** key (4) while pressing the blue trigger (1). The star-symbol indicates, if the laser is activated or not. The respective status will be stored by the instrument.

Select temperature units (degrees °C or °F) by pressing the **°C/°F** key (2). This is possible while measuring (holding the blue trigger) or between the measurements. The units will be shown on the right of the LCD.

When the meter is powered on, press Mode key to adjust the emissivity. A blinking ϵ will show on the screen and the value on the minor display becomes adjustable ranging from 0.30 to 1.0. Press \blacktriangle to increase the value, and press \blacktriangledown to decrease it. To save the adjusted emissivity value, press „MODE“ key again. Then ϵ stops blinking and the meter returns to measurement mode.

Select backlighting by pressing the **BACKLIGHTING** key (5). Repeat the procedure to turn the backlight off.

The IR-Thermometer automatically holds the last temperature reading on the LCD for 10 seconds after the trigger is released. Approximately 10 seconds after the trigger is released, the meter powers OFF automatically.

The meter automatically compensates for temperature derivations from ambient temperature. Keep in mind that it will take up to 30 minutes to adjust to wide ambient temperature changes. This is a result of the cooling process which must take place for the IR sensor.

4. Maintenance

3.2 Battery Replacement

The instrument is powered by a 9V battery. A flashing display indicates that the battery voltage has fallen into the critical region (6.5 to 7.5 V).

- Wait until the instrument has automatically turned off after 10 seconds.
- Open the battery compartment below the grip.
- Install a 9V battery and connect the cable to the battery clip.
- Replace the cover.

4. Maintenance

Clean the exterior housing with a damp cloth. Ensure that no water penetrates into the instrument or has contact with the infrared lens.

We recommend to clean the lens regularly. Use low pressure compressed air to remove any particles on the lens. If the contamination can not be removed with air, use a soft cotton swab. Any swab should be slightly damp, and very light pressure should be applied to the lens. Do not use solvents to clean the lens.

5. Information on disposal



You may hand in any defective batteries taken out of the unit to our company as well as to recycling places of public disposal systems or to selling points of new batteries or storage batteries.

In the European Union, electronic equipment does not belong into domestic waste but - in accordance with Directive 2002/96/EC of the European Parliament and of the Council of 27 January 2003 on Waste Electrical and Electronic Equipment - must be disposed of in an expert manner. If you do no longer need this unit, please dispose of it in accordance with the applicable statutory provisions.

5. Emisivity-tables

5. Emisivity-tables

5.1 Metals

Material	Emisivity (8 - 14 μm)	Material	Emisivity (8 - 14 μm)
aluminium oxidized	0,20 - 0,40	molybdenum oxidized	0,20 - 0,60
alloy A 3003 oxidized	0,30	brass polished	0,30
		oxidized	0,50
lead rough	0,40	nickel oxidized	0,20 - 0,60
oxidized	0,20 - 0,60	electrolytical	0,05 - 0,15
iron oxidized	0,50 - 0,90	iron, cast oxidized	0,70 - 0,90
rusty	0,50 - 0,70	grounding sheet oxidized	0,40 - 0,60 0,70 - 0,90
cast iron oxidized	0,60 - 0,95	stainless	0,10 - 0,80
iron, forge dull	0,90	titanium oxidized	0,50 - 0,60
		zinc non oxidized	0,05
Haynes alloyage	0,30 - 0,80	platinum, black	0,90
Inconel (Ni-alloyage) polished	0,70 - 0,95 0,30 - 0,60	copper oxidized	0,40 - 0,80

5. Emissivity-tables

5.2 Non-metals

Material	Emissivity (8 - 14 μm)	Material	Emissivity (8 - 14 μm)
asbestos	0,95	asphalt	0,95
basalt	0,70	concrete	0,95
carbon non oxidized graphit	0,80 - 0,90 0,70 - 0,80	earth dry wet	0,92 0,95
ice	0,98	ice bath	0,95
colour non alkaline	0,90 - 0,95	plastic nontransparent	0,95
gypsum	0,80 - 0,95	sheet	0,85
paper all colours	0,95	wood nature	0,90 - 0,95
rubber	0,95	lime stone	0,98
carborundum	0,90	ceramic	0,95
grit	0,95	sand	0,90
snow	0,90	cloth	0,95
clay	0,95	water	0,93
brick	0,93	finish white beamless black	0,92 0,97

7. EG-Conformity Statement

7. EG - Conformity Statement

For the following product:

Wöhler IR Temp 210

complies with the essential protection requirements of Council Directive 89/336/EEC on the approximation of the laws of the Member States relating to electromagnetic compatibility.

Assessment of compliance of the product with the requirements relating to electromagnetic compatibility was based on the following standards:

EN 61326:1997/A1:1998

EN 55011:1998/A1:2000 (Group 1, Class B)

IEC 61000-4-2:1995/A1:1998/A2:2000

IEC 61000-4-2:1995/A1:1998/A2:2000

This declaration is based on third party measurements.

8. Guarantee and Service

8.1 Guarantee

The guarantee period for the Wöhler IR Temp 210 is **12 months** from the sales date, provided that it is used correctly.

We see **SERVICE** as a very important element in our business. That is why we are still available to you even after the guarantee period has expired.

- An **immediate repair** will be carried out if you bring your meter to us in Bad Wünnenberg.
- If you send us the meter, it will be returned to you by our delivery service after repair **in just a few days**.
- We can lend you a device for a small standard fee.
- You can obtain **immediate help** from our engineers by telephone.